

DIL-2C24

High Voltage Reed Relay

PRODUCT VISUAL

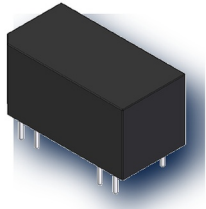

real source image

KEY RATINGS

NOMINAL COIL VOLTAGE

24 VDC

MAX PULL-IN VOLTAGE

17 VDC

MIN DROP-OUT VOLTAGE

3.6 VDC

MAXIMUM COIL VOLTAGE

30 VDC

CONTACT FORM

2 Form C / DPDT

MAX CONTACT RATING

5 W

OVERVIEW

- 14-pin dual in-line package
- 24 VDC coil, fast switching
- 2 Form C changeover contacts
- RoHS compliant; custom design

COIL DATA

Nominal Coil Voltage	24 VDC
Max Pull-in Voltage	17 VDC
Min Drop-out Voltage	3.6 VDC
Maximum Coil Voltage	30 VDC
Coil Resistance	2000 ohm ±10%

CONTACT RATINGS

Contact Form	2 Form C / DPDT
Max Contact Rating	5 W
Max Switching Voltage	175 VDC / Peak AC
Max Switching Current	0.25 A DC / Peak AC
Max Carry Current	1.5 A
Max Contact Resistance	200 mOhm
Dielectric Open Contacts	200 VDC
Dielectric Coil/Contact	1400 VDC

ELECTRICAL CHARACTERISTICS

Insulation Resistance	1E9 ohm
Operate Time	0.7 ms
Release Time	1.0 ms
Expected Life	5×10⁷ ops

ENVIRONMENTAL / OPTIONS

Vibration Resistance	20 G, 0-2000 Hz
Shock Resistance	50 G, 11 ms half-sine
Operating Temperature	-40°C to +85°C
Storage Temperature	-40°C to +105°C

MECHANICAL OUTLINE / DIMENSIONS

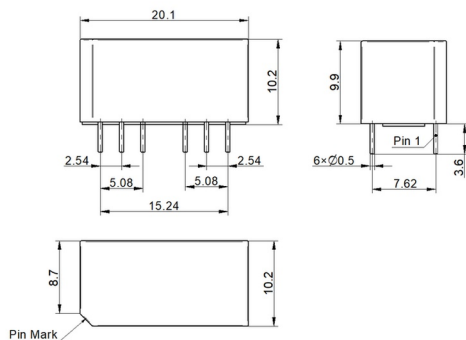

CIRCUIT / MARKING / TERMINAL VIEW

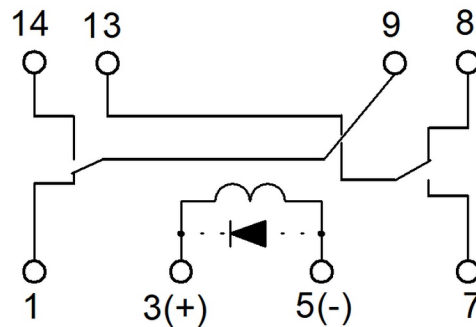

ORDERING & SOURCE TRACEABILITY

DIL-2C24 / 24 VDC / 2 Form C / Standard

Source: DIL□□□□□□□□.pdf

Technical values are preserved from source PDFs / generated metadata. Original outline and circuit figures are reused where available; do not treat artwork proportions as standalone dimensional authority.