

DIL-1C05

High Voltage Reed Relay

PRODUCT VISUAL

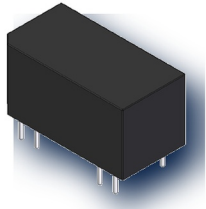

real source image

KEY RATINGS

NOMINAL COIL VOLTAGE

5 VDC

MAX PULL-IN VOLTAGE

3.5 VDC

MIN DROP-OUT VOLTAGE

0.75 VDC

MAXIMUM COIL VOLTAGE

7.5 VDC

CONTACT FORM

1 Form C / SPDT

MAX CONTACT RATING

5 W

OVERVIEW

- 14-pin dual in-line package
- 5 VDC coil, fast switching
- 1 Form C changeover contact
- RoHS compliant; custom design

COIL DATA

Nominal Coil Voltage	5 VDC
Max Pull-in Voltage	3.5 VDC
Min Drop-out Voltage	0.75 VDC
Maximum Coil Voltage	7.5 VDC
Coil Resistance	200 ohm ±10%

CONTACT RATINGS

Contact Form	1 Form C / SPDT
Max Contact Rating	5 W
Max Switching Voltage	175 VDC / Peak AC
Max Switching Current	0.25 A DC / Peak AC
Max Carry Current	1.5 A
Max Contact Resistance	200 mOhm
Dielectric Open Contacts	200 VDC
Dielectric Coil/Contact	1400 VDC

ELECTRICAL CHARACTERISTICS

Insulation Resistance	1E9 ohm
Operate Time	0.7 ms
Release Time	1.0 ms
Expected Life	5×10⁷ ops

ENVIRONMENTAL / OPTIONS

Vibration Resistance	20 G, 0-2000 Hz
Shock Resistance	50 G, 11 ms half-sine
Operating Temperature	-40°C to +85°C
Storage Temperature	-40°C to +105°C

MECHANICAL OUTLINE / DIMENSIONS

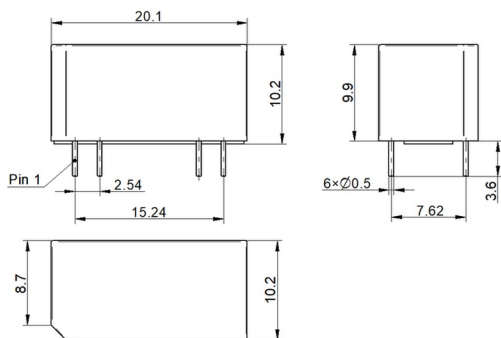

CIRCUIT / MARKING / TERMINAL VIEW

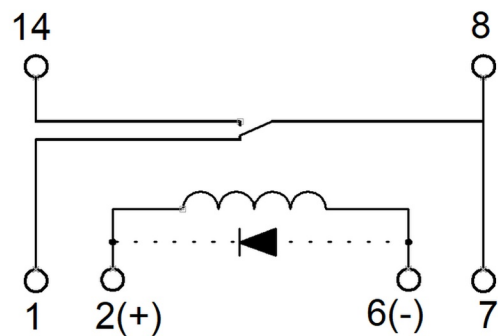

ORDERING & SOURCE TRACEABILITY

DIL-1C05 / 5 VDC / 1 Form C / Standard

Source: DIL□□□□□□□□.pdf

Technical values are preserved from source PDFs / generated metadata. Original outline and circuit figures are reused where available; do not treat artwork proportions as standalone dimensional authority.