

# MSIP-1A05S-ATE

- Hermetically sealed for long life
- Low Contact Resistance
- Excellent Lifetime Characteristics
- Custom Design Available

[Outline Dimension]

Unit: mm Scale: 1/1

Form 1A and Magnetic

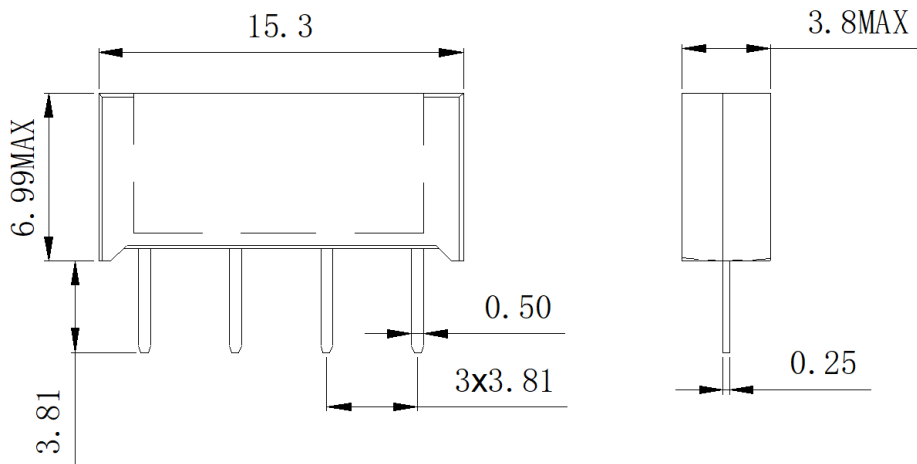

[Pin Layout]

[Wiring diagram]

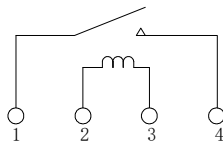

Order Information

MSIP-1A05S-ATE

Coil Parameters		Relay Parameters	
1 Nominal coil voltage	5 VDC	1 Min Breakdown Voltage	250 VDC
2 Max Operating voltage	15 VDC	2 Dielectric Strength coil/contact	1.2K VDC
3 Max Pull-in voltage	3.8 VDC	3 Insulation Resistance coil/contact	1.00E+10ohm
4 Min Drop-out voltage	0.4 VDC	4 Operate Time, incl. Bounce	0.5ms
5 Coil Resistance	400 ohm	5 Reset Time	0.3ms
Contact Parameters		6 Capacitance Across Contacts	1.0pF
1 Contact Form	1 Form A	7 Storage Temperature	-35~+105°C
2 Max Contact Rating	30 W	8 Operating Temperature	-20~+70°C
3 Max Switch Voltage	250V ACpeak/DC	9 Soldering Temperature	5 sec. max 260°C
4 Max Switch Current	1.0 A		
5 Max Carrying Current	1.5 A		
6 Min Breakdown Voltage	250 VDC		
7 Max Contact Resistance	100 mohm		

Version: 01	Designed by		TITLE	
	Checked by		High Voltage Reed Relay	
	Approved by		P/N	Scale: 1:1
	Date	17th,Nov,2023	MSIP-1A05S-ATE	Page: 1/1