

SIP-HG-1A24

- High Power Mercury Reed Relay
- Low Contact Resistance
- High Carry Current
- Excellent Lifetime Characteristics
- Custom Design Available

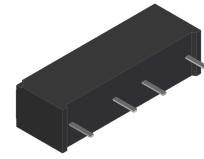

[Outline Dimension]

Unit: mm Scale: 1/1

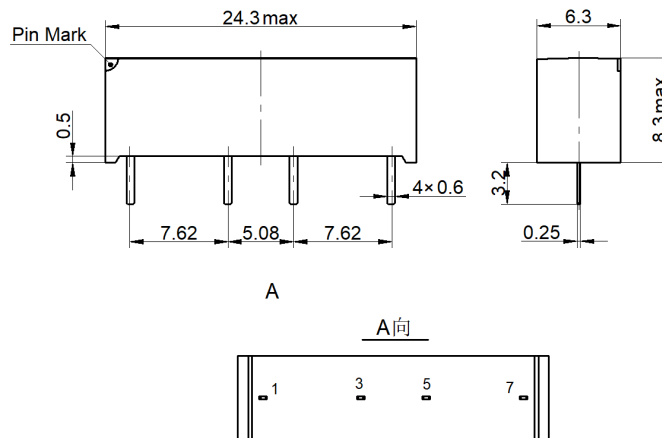

[Pin Layout]

[Wiring diagram]

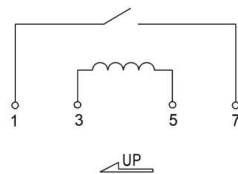

Order Information

SIP-HG-1A24

Coil Parameters		Relay Parameters	
1 Nominal coil voltage	24 VDC	1 Min Breakdown Voltage	2K VDC
2 Max Operating voltage	29 VDC	2 Dielectric Strength coil/contact	2K VDC
3 Max Pull-in voltage	18 VDC	3 Insulation Resistance coil/contact	1.00E+12ohm
4 Min Drop-out voltage	2 VDC	4 Operate Time, incl. Bounce	2.0ms
5 Coil Resistance	1440 ohm	5 Reset Time	1.5ms
Contact Parameters		6 Capacitance Across Contacts	0.3pF
1 Contact Form	1 Form A	7 Storage Temperature	-35~+105°C
2 Max Contact Rating	50 W	8 Operating Temperature	-20~+70°C
3 Max Switch Voltage	1KV ACpeak/DC	9 Soldering Temperature	5 sec. max 260°C
4 Max Switch Current	1.0 A	Note	
5 Max Carrying Current	5.2 A(at 30°C)	Hg wet contacts must be mounted within 30°	
6 Min Breakdown Voltage	2K VDC	of vertical plane.	
7 Max Contact Resistance	100 mohm		

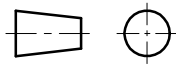
Version: 01	Designed by		TITLE	
	Checked by		High Voltage Reed Relay	
	Approved by		P/N	Scale: 1:1
	Date	31th,May,2022	SIP-HG-1A24	Page: 1/1